

Solving the Spectrum Crisis

*Charles Baylis, Matthew Fellows, Lawrence Cohen,
and Robert J. Marks II*

In 2009, the U.S. Federal Communications Commission (FCC) chair, Julius Genachowski, warned of a looming spectrum crisis [1]. Issues such as a 2010 saga involving satellite communications interfering with the global positioning system (GPS) have reminded us that spectrum is becoming an ever-precious commodity. With wireless broadband technologies evolving at a rate that will outgrow the available spectrum, the U.S. government has acted to try to “stop the bleeding.” President Barack Obama’s National Broadband Plan of 2010 [2] mandates that 500-MHz of spectrum be reallocated for wireless broadband applications. However, the continued surge in wireless spectrum users shows that even this spectrum will be used quickly and that a new paradigm is needed. Many have suggested that dynamic spectrum access (DSA), where spectrum is assigned in real time, will be the sharing protocol of the future, and that future spectrum users will be required to be frequency-flexible and cognitive. Radar systems are spectrum users that, in their present form, will have difficulty operating in this future environment because of their fixed operating frequencies, high power, and tendency to leak power into neighboring bands and interfere with other users. In 2011, National Telecommunications and Information Administration (NTIA)

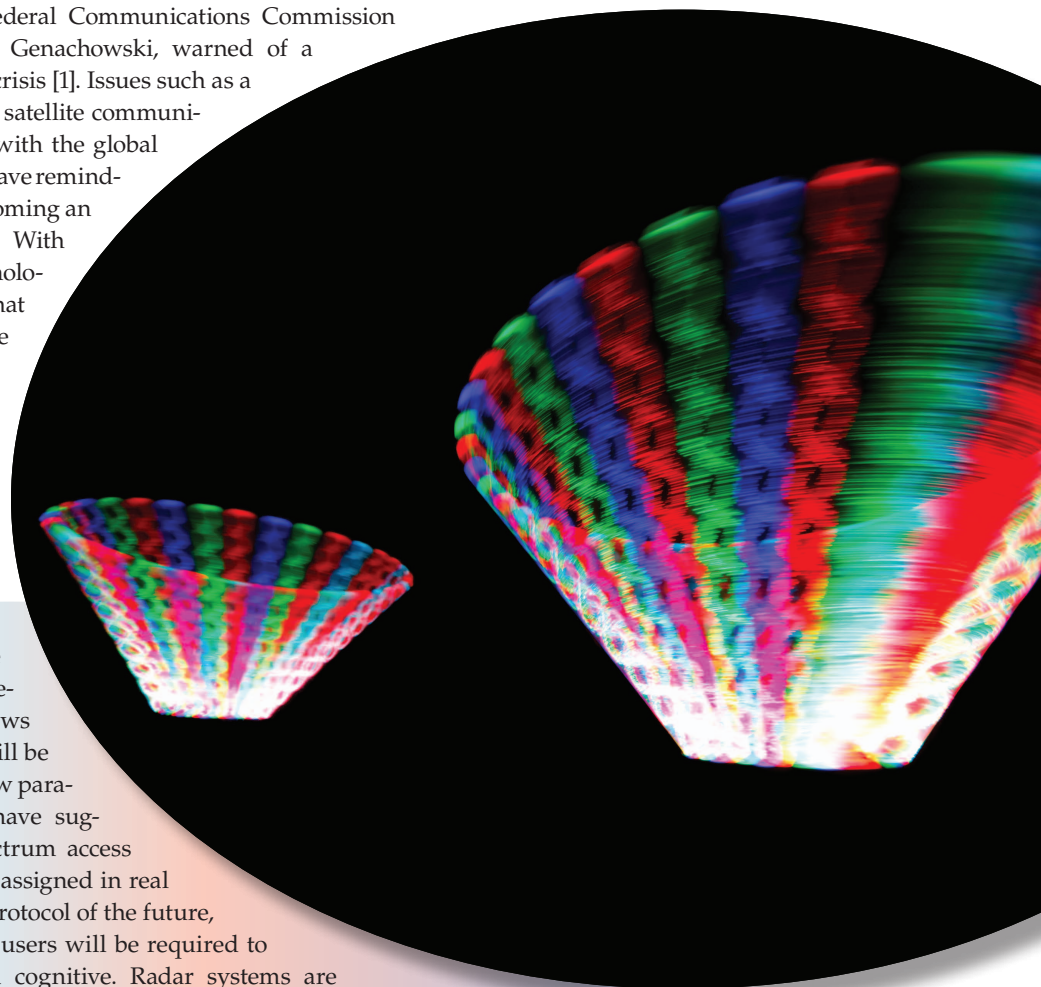

IMAGE LICENSED BY INGRAM PUBLISHING

Charles Baylis (Charles_Baylis@baylor.edu), Matthew Fellows, and Robert J. Marks II are with the Wireless and Microwave Circuits and Systems Program, Department of Electrical and Computer Engineering, Baylor University. Lawrence Cohen is with the U.S. Naval Research Laboratory, Radar Division, Washington, D.C., United States.

Digital Object Identifier 10.1109/MMM.2014.2321253
Date of publication: 11 July 2014

Chief of Staff Thomas Power stated, "The community and policy makers must begin to understand the challenges and constraints that currently exist for radar" [3]. The last three years have witnessed an upshot of radar spectrum conferences and meetings, many organized by the NTIA and the Department of Defense's (DoD's) Joint Spectrum Center. Our interest has been stimulated through encountering this issue in military radars, and in participating as speakers and panelist in many of these meetings, including a 2011 NTIA meeting for radar and communications experts to converse about coexistence challenges. However, the DoD, the FCC, and the NTIA still have not developed any technically sound solutions to achieve spectrum sharing between radar and communications. Wireless broadband expansion is not going away. The cry to radar operators is clear: radar systems must change how they operate.

Present radar systems have been shown to cause failure of wireless communications because of spectral spreading into neighboring frequency bands, as depicted in Figure 1. Because they transmit with high power and nonlinearity, their strong signals leak into neighboring bands and can interfere with transmitted communication signals. Figure 2 shows measurement results of a received constellation for a coexistence experiment involving a radar and a nearby wireless communication system using 64-quadrature amplitude modulation (QAM), as presented in [4]. The constellation diagram plots the in-phase (I) and quadrature (Q) diagram of all possible transmitted symbols in a digital 6-bit configuration (64 possible symbols). Figure 2(a) shows that the received constellation looks normal when the communication system operates without the radar present. As would be expected, 16 evenly spaced symbols are visible in each quadrant of the constellation diagram. Figure 2(b), however, shows severe degradation of the constellation when a legacy radar is operating in the neighboring frequency band. Many of the transmitted symbols are received and detected near or in regions where they would be incorrectly detected as different symbols. The radar transmitter causes degradation of the QAM constellation by leaking into the frequency band used by the wireless communication system, and drives the receiver amplifier into its nonlinear regime, causing the constellation symbols to be inaccurately read.

One potentially useful idea in solving this spectrum problem is cognitive radar, predicted by the forward thinking of Haykin [5] and Guerci [6]. A cognitive

radar, by definition, is a thinking radar: one that senses and responds to its environment. It gathers information about surrounding target and spectrum users and then adjusts its operating frequency, waveform, modulation, and other properties accordingly. Many have favored this concept due to its tactical, military-related advantages, but this idea could also allow radars to be good neighbors in the spectrum environment. To be able to adjust, Guerci acknowledges in his recent book that hardware optimization of the transmitter will be necessary [6]. More specifically, the waveform and circuit of a future cognitive radar must be reconfigurable and optimizable in real time. Initial progress has been made in the separate fields of reconfigurable circuitry and waveform optimization, detailed by Qiao [7], Baylis [8], and Patton [9], but a holistic optimization solution including the all-important aspect of the radar amplifier circuitry has not yet been presented.

A problem that must be addressed is whether future radars can operate in a situation where spectrum is dynamically allocated. Due to the fact that most of the spectrum has been allocated by regulatory agencies, but not all spectrum is simultaneously in use, many have proposed DSA as a protocol that will enhance access to the spectrum for all users. In this model, unused spectrum is temporarily available to other users. This certainly maps into the framework of cognitive radio. If a portion of spectrum is unused, any application may use it provided that it vacates when it is wanted again by its primary user. But can radar systems operate within a DSA environment? In this article, we address the ability of the radar to reconfigure its circuitry and waveform to facilitate changes in frequencies and spectrum bandwidth requirements. We investigate major issues facing the implementation of cognitive radar: how can a radar reconfigure its circuitry to be operable in different frequency bands? Also, how can a high-power radar adjust its spectrum to cooperate in nearby frequencies to sensitive communication receivers?

There are several additional problems that must be investigated beyond the present article, perhaps most notably that radar systems involving range detection require a "listen" time. This time could be misinterpreted by other users as vacating the spectrum. If another user jumps into the frequency spectrum used by the radar while it is listening, false detection information could occur. This would affect weather forecasting, air traffic control, and possibly national security. This problem must be solved by protocol experts. It is not the intent of this article to investigate this part of the problem. In addition, caution must be taken not to oversimplify the problem. Certain applications require use of a designated frequency band due to elements such as, for example, atmospheric properties and the application in which the radar is engaging. Also, many applications may be more likely to be able to sacrifice

their capabilities for certain periods of time. For example, weather radars could perhaps sacrifice their ability to detect by decreasing their bandwidth, while a military radar used for missile detection may not be able to lessen its bandwidth because tremendous risks are associated with detection failure or ambiguity.

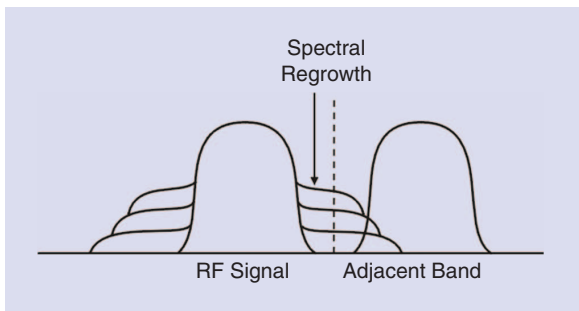

Figure 1. An example of spectral spreading intruding into adjacent bands.

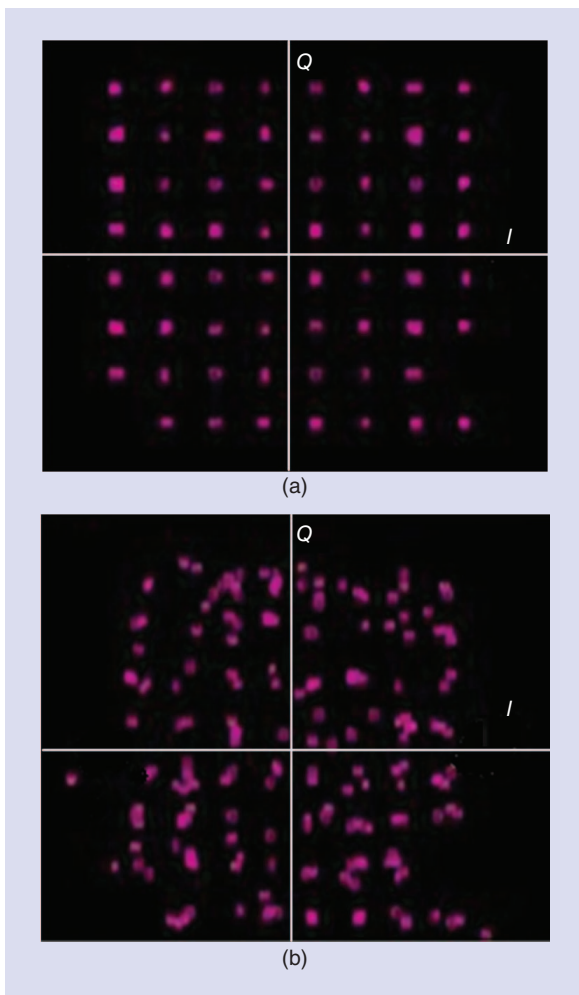

Figure 2. An I and Q symbol diagram of a received 64-QAM constellation for a wireless communication system (a) without radar interference and (b) during operation of a nearby radar system in a neighboring frequency band [4]. The adjacent-band radar interference severely degrades the received constellation.

The adjustment of transmit power, duty cycle, and protection against jamming are also pressing issues facing radar operators. Much of these topics remain to be addressed. The general challenges of DSA are reviewed significantly in the literature: articles by Chapin [10] and Zhao [11] provide good overviews of the concept and regulatory challenges.

One factor that will influence the deployment of the concepts described in this article is the expense associated with replacing many presently operating legacy radar systems. Many systems presently in operation have been operating for decades and will need to continue to operate for many more years. While certain modifications may be performed to these systems, it must be realistically accepted that the full swing to a cognitive, reconfigurable, DSA radar environment may not be complete for many years.

This article provides a philosophical look at the way forward in microwave circuit design for cognitive radar. It discusses a path to designing a reconfigurable microwave transmitter power amplifier that, through real-time optimization of its matching circuitry and waveform, will enable the cognitive function of a radar to perform to its potential. While we have written multiple journal and conference papers and manuscripts about the enabling technology for this approach, the purpose of this article is rather to provide a philosophy of design for the next radar, and to tie together the technical contributions in this research area by all involved toward accomplishing this future radar: a radar that is sensitive to its environment and adaptive to meet the changing spectrum requirements of today's world.

The Problem

Government spectrum allocations are enforced on radar systems in terms of spectral masks, as shown in Figure 3 [12]. The spectral mask provides the confines within which the transmitted spectrum must abide. In the United States, spectral mask requirements for government-allocated spectrum are given by the NTIA. For commercial spectrum, the spectral mask is provided by the FCC. Allocations are becoming increasingly stringent and are pushing the technical limits of operation for present-generation radar systems.

To operate as part of a sustainable environment, high-power radar RF circuit components must be run in a power efficient mode which, unfortunately, forces them into nonlinear operating regions. Nonlinearities are a significant source of spectral spreading in radar transmitters, causing intermodulation of in-band frequencies that leads to frequency content spreading outside the band of the originally transmitted signal [13], [14]. Therefore, linearization of the transmitter power amplifier is important to reduce spectral spreading. The adjacent-channel power ratio (ACPR) is a useful metric to measure out-of-band distortion

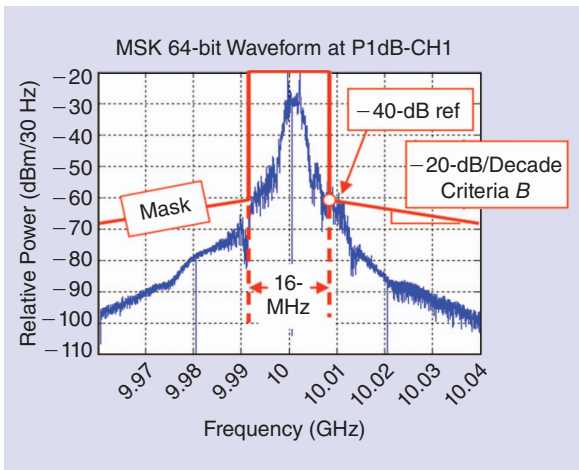

Figure 3. Spectral mask for a typical radar channel, reprinted from [12].

due to system nonlinearities [15], and is the ratio of the power in a defined adjacent channel to the in-band power:

$$\text{ACPR} = \frac{P_{\text{adjacent}}}{P_{\text{in-band}}} \quad (1)$$

A useful measure of the circuit efficiency is the power-added efficiency (PAE) of the amplifier. The PAE describes what percent of the dc input power is converted into RF output power, and is defined as follows:

$$\text{PAE} = \frac{P_{\text{out,RF}} - P_{\text{in,RF}}}{P_{\text{dc}}} \times 100\% \quad (2)$$

The ACPR and PAE metrics provide quantitative expression of linearity and efficiency for numerical optimization.

As is well known to microwave circuit designers, linearity and efficiency are conflicting objectives: under the operating conditions where an amplifier's transistor operates with high efficiency, it is also significantly nonlinear. Figure 4 shows the simulated gain and PAE plotted against input power for a power amplifier we designed. At the input power for which the PAE reaches its maximum of 57%, the gain is compressed nearly 2-dB. This shows that the linearity versus efficiency is a tradeoff where a "best compromise" through Pareto optimization must be accepted in most designs.

The tradeoff between linearity and efficiency in power amplifier design is a well-studied problem. Where possible, amplifier linearization techniques that are presently used in communication systems should be applied to radar systems. Amplifier linearization techniques include envelope tracking, envelope elimination and restoration, the Doherty configuration, push-pull design, and other approaches [15], [16]. More new radar transmitters will likely be built using solid-state technology as the power-handling capability of gallium nitride (GaN) continues to rise. Linearization

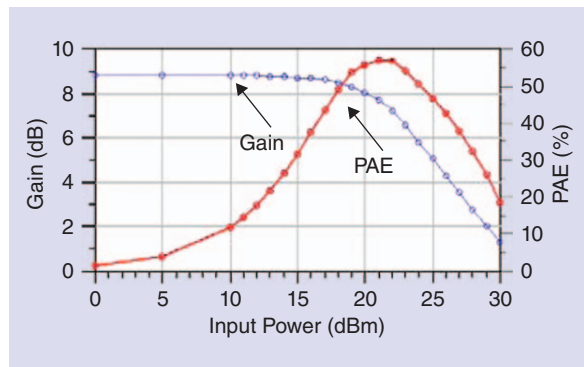

Figure 4. Simulated gain and PAE versus input power for a GaAs PHEMT power amplifier.

of the amplifiers is important because it eliminates as much spectral spreading as possible through the circuit design, while maintaining acceptable power efficiency.

In addition to the amplifier matching network, the radar waveform can be a source of unwanted spectral spreading. Significant attention has been given in the literature to waveform design for bandlimited transmission. Spectrally confined waveforms can be generated by proper choice of modulation or windowing [17]–[19]. However, many windowing approaches can also reduce the transmitted power, lowering overall efficiency. As such, variable-modulus techniques can cause large amounts of power to be wasted in radar transmission, as compared to constant-modulus waveforms, which are more desirable for high-efficiency transmission.

Transmitter for a Cognitive Radar

The idea for a cognitive radar is not new. Haykin [5] and Guerci [6] have suggested that a radar system should be able to respond to its surroundings and have developed this concept. Much of the literature, however, focuses on the software part of the cognitive radar: how the system should strategically respond to the location of possible targets, interferers, and other spectrum users. The fact that the microwave circuitry of the radar transmitter must be flexible to accommodate the desired real-time changes in the frequency of operation dictated by the "brain" of the cognitive radar is often overlooked. However, this area may prove to be the most challenging area of developing the cognitive radar: creating the RF enabling technology to make it happen.

The concept of a future radar transmitter is illustrated in Figure 5. The power amplifier is fed by a signal generator whose waveform is controlled by a field-programmable gate array (FPGA) controller, the brain of the cognitive radar. The controller also operates a tunable load network. On-chip capabilities for a future radar system must include spectrum analysis and power sensing, as well as capabilities to calculate the ambiguity function of the output waveform. These measurements will be used to optimize the

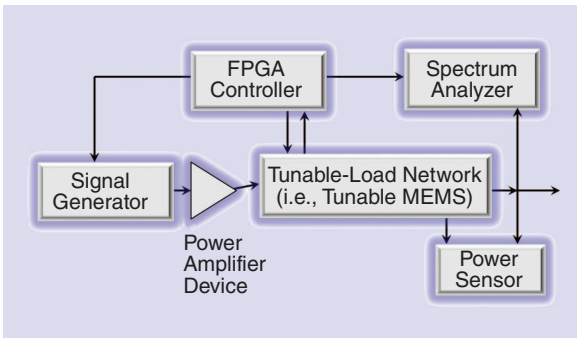

Figure 5. Future radar transmitter.

transmitter's performance in real time. Creating this transmitter is the focus of our research.

What is the research path toward achieving this cognitive radar transmitter? We believe that the path to success for this transmitter is to focus on the following areas:

- Load-matching network optimization techniques for efficiency and spectral mask compliance.
- Waveform optimization for desired ambiguity function properties and spectral mask compliance.
- Joint, simultaneous waveform and matching-network optimization for desired ambiguity-function properties, efficiency, and spectral mask compliance.
- Use of additional information sources to speed the real-time search optimization, such as the S-parameters and X-parameters.
- Dynamic radar spectral mask construction based on the relative locations of the radar transmitter and communication nodes.
- On-chip implementation of functionality, including control from an FPGA software-defined radio platform.

Completion of this research road map will create a real-time adaptable radar transmitter that can meet changing spectral mask requirements, and can reconfigure to operate in different frequency bands. We now proceed to summarize some of the initial research that has been performed by our group and others toward the radar transmitter, and then to forecast the research path necessary to develop this transmitter.

Load-Matching Network Optimization

For a radar system to change its band of operation, its circuitry must be able to change. Furthermore, the linearity and efficiency of an amplifier are functions of load reflection coefficient. Load-pull measurement is a common microwave measurement that allows the load impedance to be adjusted to find the optimum of some objective (such as power, efficiency, or ACPR). Figure 6 shows an example of load-pull. A criterion for which an amplifier is being designed is chosen, such as the output power, gain, PAE, or ACPR, and the criterion is measured for several values of load reflection coefficient. Contours connecting points estimated to

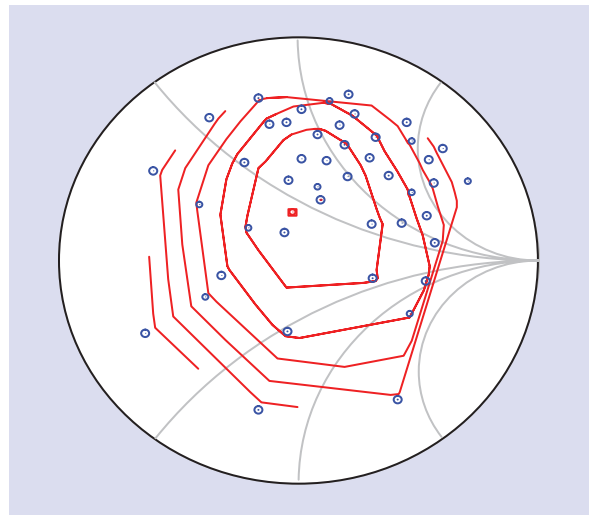

Figure 6. A load-pull measurement example. The dots represent load reflection values for which the criterion (i.e., output power, gain, PAE, ACPR) is measured. Level-curve contours representing different values of the criterion, and the optimum point, are fit to the data, as shown.

possess equal values of the criterion are constructed to the data, and the optimum reflection coefficient for the criterion is estimated, represented by the square point shown in Figure 6.

In the 1990s, Sevic and his colleagues published their early work in ACPR load-pull [20], [21]. Wu et al. connect ACPR measurement data for broadband signals with predictions based on third- and fifth-order intermodulation measurements from two-tone excitation tests [22]. The technology to support reconfigurable matching circuits has also been developed, beginning in the early 2000s. Lu et al. as well as Vaka-Heikkila and Rebeiz describe the use of microelectromechanical systems (MEMS) switches to build reconfigurable amplifiers with adaptive output matching networks [23], [24]. Deve et al. describe the design of an adaptive impedance tuner for the 1–3-GHz range, a frequency range applicable to many communications and sensing applications [25]. In his 2011 paper, Sun connects the concept of adaptive impedance matching to high-efficiency transmitter operation. He describes an adaptive “automatic antenna tuning unit” to provide the transceiver feed-point impedance [26]. This paper identifies three areas of needed future research in reconfigurable matching networks: 1) impedance matching, 2) simple impedance sensor design, and 3) intelligent algorithms to minimize the number of iterations in impedance matching. The third area will be critical to the development of the next-generation cognitive radar and is of pertinent interest to microwave engineers.

Fast impedance matching, i.e., quick tuning of the load impedance in real time, has been documented. For real-time, reconfigurable radar transmitters, fast impedance matching will be necessary to allow radars to change frequency bands of operation, and to meet

differing spectral emissions requirements and power efficiency demands. Sun and Lau demonstrate the use of a genetic algorithm to perform antenna impedance matching based on the voltage standing-wave ratio (VSWR) [27], [28]. Du Plessis and Abrie examine the use of genetic algorithms and conclude that genetic algorithms can be slower than other algorithms [29]. Other candidate optimization approaches have been proposed in the literature, including fuzzy control [30], neural networks [31], least-squares optimization [32], and our work in convex optimization and steepest ascent [8], [33]. Qiao et al. demonstrate the use of a MEMS-reconfigurable network for real-time tuning using a genetic algorithm [7].

We began our work toward load matching-network optimization through the development of a steepest-ascent algorithm to optimize the output power through a fast load-pull measurement [8], [33]. Figure 6 shows the results of optimizing the load reflection coefficient Γ_L to provide maximum output power. This optimization is a function of two variables: $Re(\Gamma_L)$ and $Im(\Gamma_L)$. The approach is based on the application of the steepest ascent algorithm as described by Wilde [34] to the optimization of reflection coefficient to maximize power. Figure 7 shows measurement search results for a field-effect transistor (FET), associated load reflection coefficient, and, in Table 1, the number of queries required for each of four starting Γ_L values used in the search. Excellent correspondence is obtained between the optimized output power values and corresponding optimum values of Γ_L for the different search starting points.

The power added efficiency and ACPR are dependent on the load reflection coefficient. PAE and ACPR can be easily used as the metrics to represent the power efficiency and the spectral spreading, respectively. Figure 8 shows the measurement of ACPR using a spectrum analyzer. The adjacent channels and the main channel are selected by the user, and the total power measured in the adjacent channel (either upper or lower adjacent channel) is related to the total power measured in the defined main channel. This gives the ACPR in dBc.

Figure 9 shows load-pull data for PAE and ACPR, taken for a Skyworks packaged amplifier, with a chirp waveform used as the input signal. The plot shows that PAE and ACPR are both functions of the load reflection coefficient Γ_L . The optimum load impedance lies on a curve between the two optima known as the “Pareto front.” Pareto optimization is an optimization involving at least two conflicting objectives; in most cases, Pareto optimization is necessary when the well-known “engineering tradeoff” situation is

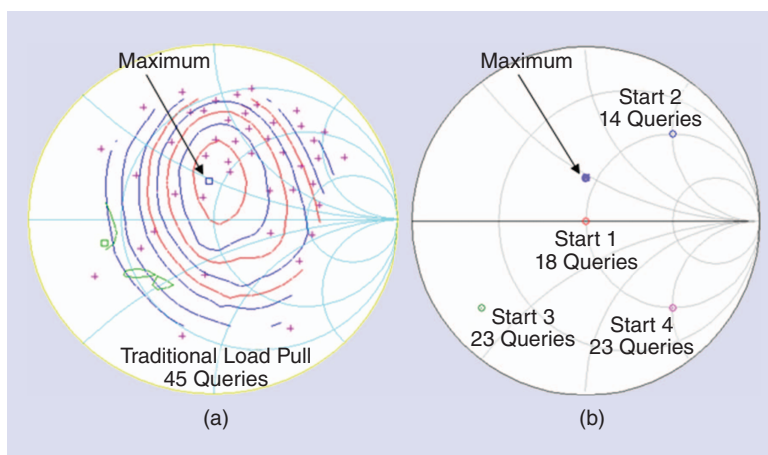

Figure 7. (a) Traditional load-pull measurement data for output power and (b) search algorithm progress for five different starting points [8].

encountered. Such a tradeoff is encountered between the objectives in this problem: efficiency (PAE) and linearity/spectral confinement (ACPR). The Pareto optimum Γ_L for this optimization is the value of Γ_L providing the largest PAE falling under the maximum allowable ACPR for the given application. Details on how the Pareto optimum can be determined from a set of load-pull data are provided in [35].

A two-step search algorithm has been developed to maximize the PAE while maintaining ACPR below a specified value, detailed in a recently published master’s thesis [35]. The initial two-step algorithm finds the PAE optimum using two gradient searches. The first gradient search finds the Γ_L value resulting in maximum PAE, and the second gradient search slowly progresses toward the ACPR minimum, terminating when an acceptably small value of ACPR is obtained. Figure 10 shows an example of this search in the measurement of the Skyworks device. A traditional load-pull measurement for the device, with the PAE and ACPR contours, is shown in Figure 10(a). Figure 10(b) shows the candidate points used in the gradient searches to find the Pareto optimum. A total of 37 measured Γ_L values are used in this search: 21 measurements are used to

TABLE 1. Measurement results for Γ_L optimization for output power from different starting points [8].

Starting Γ_L	Maximum Output Power Γ_L	Maximum Output Power (dBm)	Number of Queries
$0 + j0$	$0.233 < 86.1^\circ$	28.2962	18
$0.5 + j0.5$	$0.246 < 89.9^\circ$	28.3132	14
$0.5 - j0.5$	$0.261 < 92.0^\circ$	28.3220	23
$-0.5 - j0.5$	$0.256 < 90.7^\circ$	28.3134	23



Figure 8. A spectrum analyzer measurement of ACPR. The adjacent channels and main channel are indicated. ACPR is measured by relating the total power in one of the defined adjacent channels to the total measured power in the main channel.

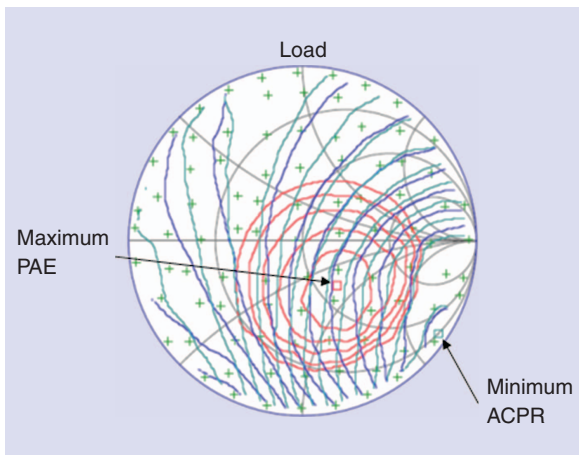

Figure 9. Output power and ACPR load-pull results for chirp waveform.

find the optimum PAE and another 16 are used to find the Pareto optimum. Table 2 shows the measurement results for multiple starting locations.

The results correspond well between the different starting points. However, the number of measurements is significantly larger than a search for the maximum PAE without a constraint on the ACPR. The question arises: could a search be designed in which the Pareto optimum can be directly found (rather than

finding the PAE maximum first), further reducing the number of measurements?

To reduce the number of measurements, a direct, vector-based search for the Pareto optimum was designed, which is detailed in [36]. This search is based on the PAE and ACPR gradient vectors, and can achieve a desired Pareto optimum Γ_L with a significant reduction in the number of experimental queries. Figure 10 shows the results of this algorithm. Figure 11(a) shows the traditionally measured load-pull contours, with the PAE and ACPR optimum points indicated. Figure 11(b) shows the Pareto optimum value for Γ_L providing the maximum PAE while keeping ACPR below -28.2 dBc. Figure 11(c) shows the results from the new, direct algorithm and Figure 11(d) shows the results using the previous two-step algorithm. It can be seen that up to 50% reduction of the number of experimental queries is possible by using the direct algorithm in this comparison [36]. Table 3 shows that the end values of PAE all correspond nicely, and that between 40 and 50% reduction in the number of experimental queries can be obtained in the best case [36].

Waveform Optimization

The waveform is related to spectral spreading as well. The waveform provides a critical function of the

radar: its ability to detect the range and Doppler of the target. Certain waveforms are better for range detection; others are better for Doppler detection. The ambiguity function is a measure of the waveform's range and Doppler detection characteristics. It is defined by the following expression [37]:

$$\chi(\tau, u) = \int_{t=-\infty}^{\infty} x(t)x^*(t-\tau)e^{-j2\pi ut} dt, \quad (1)$$

where $x(t)$ is the transmitted signal, τ is the ambiguity (error) in time delay with the actual time delay associated with the target, and u is the ambiguity in Doppler frequency with the actual Doppler frequency of the target. The ambiguity function $\chi(\tau, u)$ is a measure

of the range-Doppler correlation output over offsets in time and Doppler from the true range/Doppler state of the target. Ideally, the correlation (and also the ambiguity function) is nonzero only for $\tau = 0$ and $u = 0$. Combinations of range τ and Doppler u for which the ambiguity function is not zero show the weaknesses (ambiguities) of the radar's detection capabilities.

The ambiguity function of a radar's transmitted waveform describes the radar's capability of accomplishing its detection objectives. For example, a radar that must detect range accurately, but for which Doppler detection is not a concern, must have very low ambiguity along the τ axis, while ambiguity along the u axis is permissible. Likewise, a radar focused on Doppler detection must have low ambiguity along the u axis, while ambiguity along the τ axis is acceptable.

The ideal waveforms for range and Doppler detection are the time-domain impulse and sinusoid, respectively. Figure 12 shows the ambiguity function magnitude for a time-domain impulse function, as simulated by MATLAB. The ambiguity is aligned along the u axis, showing that large errors in Doppler

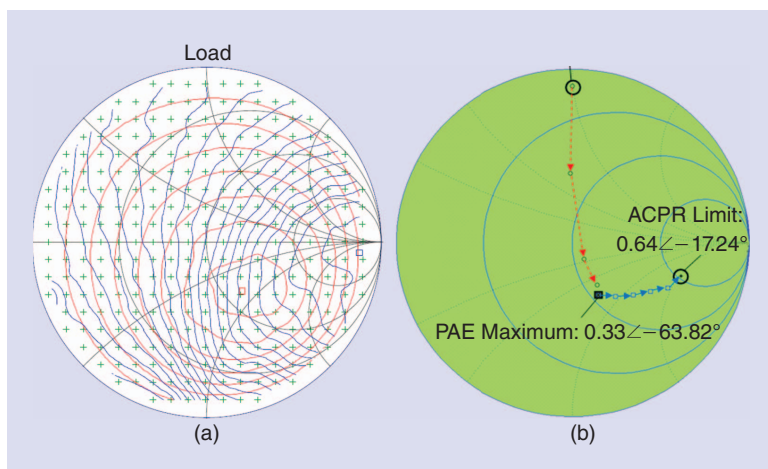

Figure 10. (a) Traditional load-pull data for PAE (red) and ACPR (blue) and (b) search algorithm progress for the optimum efficiency possessing ACPR < -29.4 dBc.

detection are likely. However, the ambiguity along the τ axis is very low, indicating that this waveform is ideal for range detection. Calculating the ambiguity function for the impulse $\delta(t)$ gives the following:

$$\chi(\tau, u) = \int_{t=-\infty}^{\infty} x(t)x^*(t-\tau)e^{-j2\pi ut} dt$$

$$\chi(\tau, u) = \int_{t=-\infty}^{\infty} \delta(t)\delta(t-\tau)e^{-j2\pi ut} dt.$$

The sampling property of the impulse function takes effect here; this gives

$$\chi(\tau, u) = \delta(-\tau) \int_{t=-\infty}^{\infty} \delta(t) dt$$

$$\chi(\tau, u) = \delta(-\tau).$$

This function becomes infinite for $\tau = 0$ and is zero for $\tau \neq 0$. This matches the depiction of Figure 12.

On the other hand, the ideal time-domain function for Doppler detection is the time-domain sinusoid. Figure 13 shows the simulated ambiguity function

TABLE 2. Measurement results for two-step Γ_L optimization for maximum PAE with ACPR < -29.4 dBc from different starting points.

Starting Γ_L	Maximum PAE Γ_L	Maximum PAE (%)	Number of PAE Points	Pareto Optimum Γ_L	End ACPR (dBc)	Number of ACPR Points
0.9 < 90°	0.33 < -63.8°	7.72	21	0.64 < -29.5°	-29.5	16
0.9 < 0°	0.40 < -56.7°	7.78	18	0.59 < -19.2°	-29.4	13
0.9 < -45°	0.47 < -44.5°	7.59	15	0.61 < -16.5°	-29.5	10
0.9 < -135°	0.39 < -41.0°	7.84	21	0.58 < -16.1°	-29.4	10
0.9 < 180°	0.40 < -48.8°	7.85	24	0.66 < -17.3°	-29.5	13
0 < 0°	0.46 < -73.5°	7.08	12	0.65 < -15.3°	-29.5	19

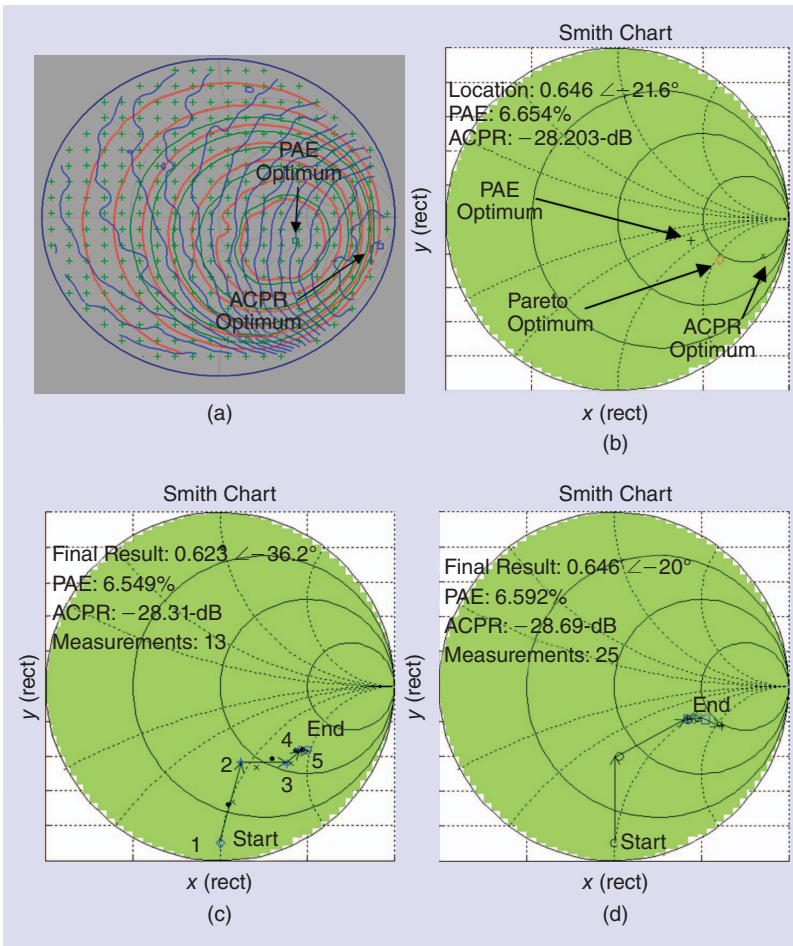

Figure 11. (a) Traditional load-pull contours, (b) Pareto optimum extracted from traditional load-pull contours, (c) new algorithm search path and result, and (d) results of the two-step comparison algorithm [36].

magnitude for the sinusoid. The noninfinite length of the main ambiguity ridge is due to the finite time of the simulated waveform.

These results can be understood more intuitively through the analysis of equation similar to the development of the impulse, albeit a slightly more involved concept. Some general notes to make is that the ambiguity is mainly aligned along the time axis, with artifacts

in some nonzero Doppler states. Because a finite-duration sinusoid was used, the time ambiguity does not extend to infinity in both directions along the τ axis. This actually leads to the correct hypothesis that a pulsed sinusoid can be used to detect both range and Doppler: the finite duration of the waveform allows the range to be ascertained, while the sinusoidal content allows a Doppler shift to be measured.

The waveform can also be optimized in radar systems to manage the tradeoff between a desired spectrally confined output and needed range/Doppler properties. The range/Doppler detection capabilities are manifested in the ambiguity function of the radar waveform. While Skolnik also states that synthesizing waveforms with desired ambiguity properties is a difficult task [37], meaningful progress has been made in this area. Woodward's classic work on ambiguity functions clearly associates waveforms with different detection properties [39]. Wilcox proposes optimizing waveforms to provide desired ambiguity functions by using a type of waveform synthesis [40]. Gladkova and Chebanov present a motivation for emphasizing the region of the range-Doppler

plane near the origin for low ambiguity: if the ambiguity is significant near the origin, the desired target can get lost in other targets or decoys, or the detection may be susceptible to jamming efforts [41]. They present an approach using Hermite waveforms as basis functions for waveform construction, and they demonstrate an approach that minimizes the volume under the ambiguity function surface over a given connected region of

TABLE 3. Measurement results for different starting reflection coefficients and comparison between algorithms [36].

Starting Γ_L	End Γ_L	End PAE (%)	End ACPR (dBc)	New Algorithm from [36] Number of Points	Two-Step Algorithm [35] Number of Points	% Red
0.9 $<$ -90°	0.623 $<$ -36.2°	6.55	-28.31	13	25	48%
0.9 $<$ 90°	0.592 $<$ -4.81°	6.67	-28.30	17	31	45%
0.9 $<$ 180°	0.621 $<$ -17.2°	6.53	-28.28	22	40	45%
0.9 $<$ 0°	0.584 $<$ -8.99°	6.74	-28.32	11	22	50%
0	0.580 $<$ -17.7°	6.88	-28.28	13	25	48%

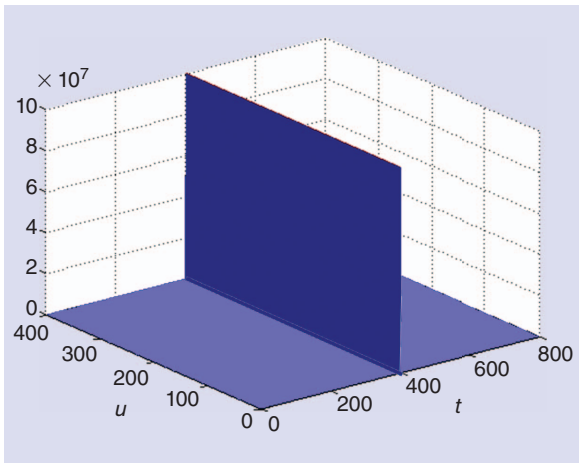

Figure 12. The ambiguity function magnitude for a time-domain impulse.

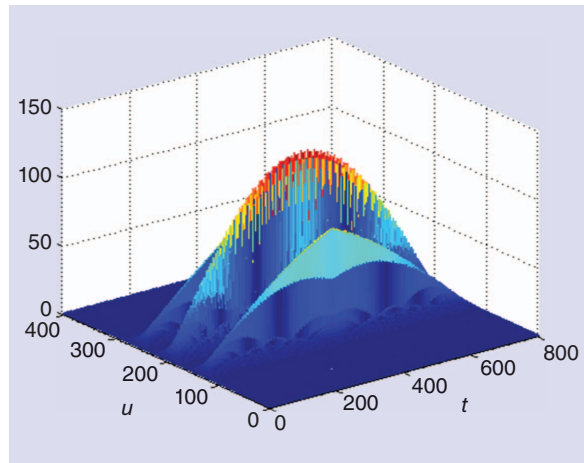

Figure 13. The ambiguity function magnitude for a time-domain sinusoid [38].

the range-Doppler plane [41], [42]. Sen and Nehorai provide an adaptive technique for spectrum design of an orthogonal frequency division multiplexing (OFDM) radar waveform to improve the wideband ambiguity function. They explain that the OFDM waveform is useful because its multiple carriers can accurately detect features of targets containing varying scattering properties across their surfaces. Their approach to optimization is also to minimize the ambiguity function over a limited region of the range-Doppler plane containing the origin [43]. Patton demonstrates optimization of the linear frequency-modulation (LFM) chirp through nonlinear Fourier series perturbations to the phase [9]. Holtzman and Thorp use the ambiguity surface as a weighted error criterion for waveform optimization [44]. Wong and Chung use genetic algorithms to minimize the ambiguity function volumes in different regions of the range/Doppler plane [45]. Sussman applies least-squares optimization to the radar waveform problem [46]. Blunt et al. and Cook demonstrate the use of continuous-phase modulation (CPM) to minimize the spectral spreading of waveforms [47], [17].

The LFM chirp is a waveform whose time and bandwidth properties can be easily modified to accomplish different ambiguity-function objectives. Skolnik states that the bandwidth of a linear chirp with fixed time length can be adjusted to “tilt” the ambiguity ridge in the range-Doppler plane [37]. In our recent paper using minimax optimization, the spectral mask constraints are additionally taken into account in optimizing the waveform [38]. For each candidate chirp considered in the optimization, the chirp must meet the spectral mask requirements or it is not given further consideration. Several critical range/Doppler combinations are chosen for which low ambiguity is strongly desired. The waveform chosen is the chirp with the lowest maximum value over the selected range-Doppler combinations. The motivation for this is the following: a radar

system may care about multiple targets; however, poor detection of just one target, even if the average detection among all of the targets is respectable, could be very detrimental. The minimax approach ensures that the waveform chosen has the best “worst-case” behavior. A sample “winner” of the ambiguity function search is shown in Figure 14. The range/Doppler points for ambiguity minimization are denoted by arrows. The frequency-versus-time and baseband spectrum plots are also shown. The chirp is seen to meet spectral mask requirements. The arrows depict the points for which low ambiguity is desired. While some significant factors are not considered in this optimization, such as the dependence of signal-to-noise ratio on the bandwidth of the waveform (and matched receive filter), the optimization approach represents a start to integrating detection properties of the radar with spectral requirements in the selection of a waveform.

The Way Forward

A paradigm shift is necessary for future radar systems for multiple reasons. First, radar systems transmit with high power and a significant degree of nonlinearity, making it difficult for other spectrum users to operate in collocated frequencies. Second, DSA is emerging as a protocol for the future assignment of wireless spectrum, so future wireless systems must be frequency agile and reconfigurable to fit into this protocol. Third, the spectral environment around radar systems, especially shipboard and aircraft systems, is often changing, so the spectral limitations placed on the radars may also change based on the wireless users in the surrounding area.

Based on these considerations, reconfigurability (at all levels) is a key component of the next-generation cognitive radar. To change operating frequency and adjust spectral output based on surrounding, intelligently reconfigurable circuitry (and governing rules for operation) is necessary. While many of this

The power added efficiency and ACPR are dependent on the load reflection coefficient. PAE and ACPR can be easily used as the metrics to represent the power efficiency and the spectral spreading, respectively.

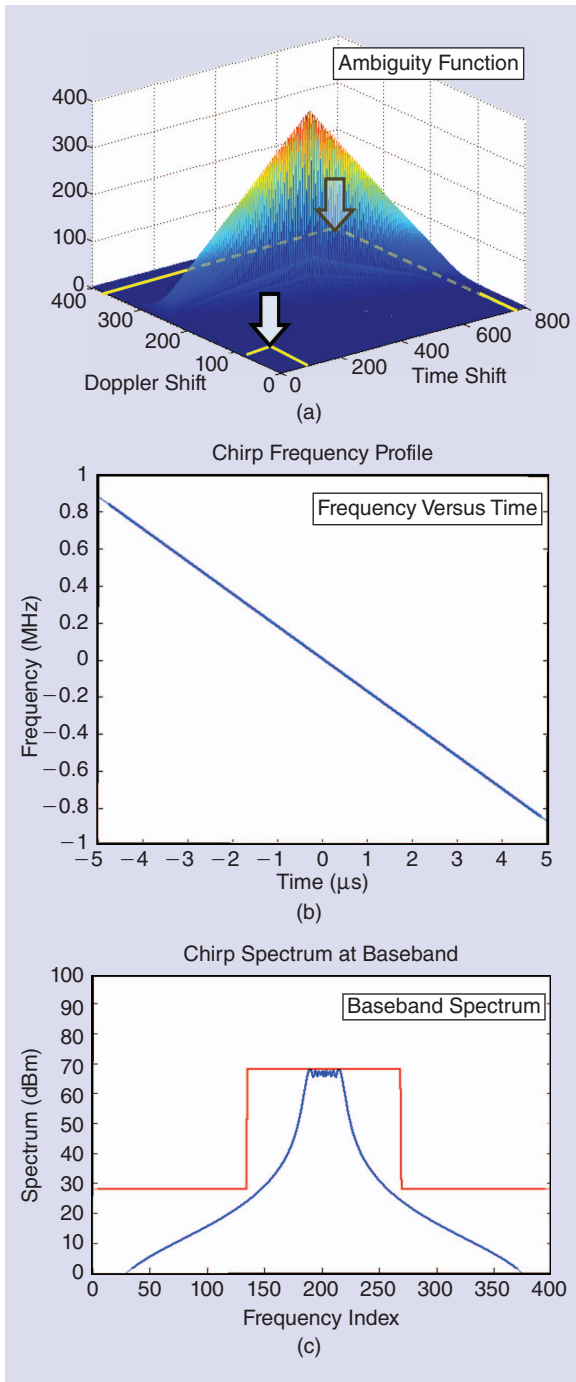

Figure 14. (a) The ambiguity function with minimization points denoted by arrows, (b) frequency-versus-time characteristics for the selected optimum chirp, and (c) chirp spectrum for the selected optimum chirp [38].

system's initial developers have focused on the software ideas and signal processing of such a system, it is evident that microwave engineers must play a significant role in the next-generation radar's innovation and creation. The development of future radar systems will require an interdisciplinary effort between microwave hardware designers, software designers, signal processing experts, and regulators. Only an interdisciplinary effort will meet the varied challenges of the cognitive radar and solve this significant part of the spectrum crisis.

Concerning the part of the cognitive radar addressed by this article, the following research steps will be necessary:

- 1) *Design a fast, real-time circuit optimization that targets linearity and efficiency.* This effort is well underway, as shown previously. Published experiments show clearly that both PAE and ACPR are a function of the load reflection coefficient Γ_L . An intelligent, fast search is needed to be able to optimize these efficiency and linearity metrics to ensure the system operates as efficiently as possible while meeting the spectral mask requirements. The vector-based search designed by our group is one candidate search technique. Other possibilities that should be explored are paraboloid-based surface approximation and Zadeh convex modeling.
- 2) *Design a real-time radar waveform optimization for spectral compliance and desired detection/ambiguity properties.* The radar waveform must be optimized so that the amplifier's output waveform achieves the desired range/Doppler detection capabilities while meeting spectral mask requirements. As described previously, several research groups have attacked waveform optimization from different angles. However, very few have included the spectral mask requirements as part of the optimization. The approach of CPM by Prof. Shannon Blunt at the University of Kansas and the approach of linear frequency modulation chirp modulation optimization by our Baylor research team are two approaches that may be useful. However, an important quality must be added to these approaches: the waveform optimization search should be intelligent, reducing the number of required measurements for the optimization. To create an intelligent search, it will be helpful to assess and catalog correlation patterns between waveform types and their ambiguity functions. Using an intelligent search may reduce the number of experimental queries (and reconfiguration time) to the point where multiple waveform classes can be simultaneously considered for the optimization. Another important step, being considered by the research teams at University of Kansas and Baylor University, is the optimization based on the ambiguity function of the amplifier's output

waveform. This is the waveform that is transmitted and will reflect off of the target. Because the nonlinear amplifier may significantly distort the waveform, it is important to base the waveform optimization on the output waveform. This leads to a type of predistortion that will be built into the real-time optimization; however, this approach is different than other well-known predistortion techniques [16]. The resultant waveform ambiguity function should be evaluated based on the ambiguity function of the output waveform, the spectral compliance, and the number of experimental queries required to perform the optimization.

- 3) *Design an algorithm for simultaneous, real-time optimization of the waveform and matching network in the reconfigurable radar transmitter.* General optimization theory states that the simultaneous optimization of two parameters may reach a higher-fitness solution than the individual optimization of the two parameters. In developing simultaneous optimization with the parameters of the load matching network and the waveform, the combined influences of load reflection coefficient and waveform characteristics on the three overarching objectives of the overall problem should be assessed. These overall objectives are detection (described by the ambiguity function), power efficiency, and spectral compliance. This step will be useful in gaining intuition toward building a joint optimization. Machine learning techniques should also be used to relate output waveforms with input waveforms based on previous measurements in the intelligent optimization. This information will allow the algorithm to “learn” and become more efficient in finding solutions.
- 4) *Investigate the use of linear and nonlinear network parameters to speed the circuit and waveform optimization.* Involving a priori knowledge in executing a search may be able to quicken its convergence to an optimal solution. Linear information about a device, such as its S-parameters, may provide a reasonable starting point in predicting the optimum load reflection coefficient for power efficiency; at least, a search may be able to be accomplished with fewer experimental queries when starting from this linear gain optimum. However, S-parameters are limited in providing information concerning the linearity (spectral spreading) of a device. Nonlinear network parameters, such as the X-parameters and S-functions, can provide very useful linearity input (including the dependence on load impedance and input waveform). Recently published work by our group explaining X-parameters [48] and nonlinear network parameters for time-invariant

Reconfigurability (at all levels) is a key component of the next-generation cognitive radar.

periodicity preservation systems [49], [50] incite ideas on how these nonlinear network parameters will be applicable in such a situation.

- 5) *Investigate dynamic radar spectral mask construction based on the relative locations of the radar transmitter and communication nodes.* In the future, spectrum allocation will be based on occupancy. In different situations, frequency agile radar systems will be placed into different spectral surroundings. In some cases, the spectral mask will be tight due to the presence of wireless operators in the neighboring bands. In other situations, the part of the spectrum near the radar’s operating band may not be heavily occupied, and the radar may be able to afford more spectral spreading. This step of the work sets the framework for how a cognitive, adaptive radar will respond to its spectral environment. If a radar system is made aware of the locations of nearby wireless communication nodes, for example, and it also knows how much interfering power can be tolerated by these communication receivers at their frequencies of operation, then this can be coordinated with the amount of power the radar is able to transmit at these frequencies without fatally interfering with the communication systems. Knowing the acceptable radar transmitter power at the frequencies of nearby communication systems will allow a spectral mask to be constructed for the radar’s transmission. Because the radar will possess the flexibility to reconfigure its matching circuitry and waveform, it will then reconfigure to fit the spectral mask. In situations where the spectral mask is tighter, the radar will sacrifice power efficiency and, in some cases, detection capabilities to operate more linearly. However, if the spectral mask is not as stringent in a less populated spectral environment, then it will allow more spreading to gain higher power efficiency and meet its standards for detection.
- 6) *Construct a reconfigurable transmitter amplifier controlled from an FPGA software-defined radio platform.* This prototype construction will be necessary to understand the practical implementation of intelligent waveform and circuit reconfiguration. This step will combine the results of algorithmic design into a practical prototype amplifier. The expected outcome of this research step is an amplifier with a variable load matching network implemented using tunable MEMS or varactor-based



Figure 15. Charles Baylis explaining spectrum analyzer measurements in a high school classroom.

technology. This step will tackle research hurdles in the practical implementation of the circuit and waveform reconfiguration discussed previously.

Engaging the Community

The spectrum crisis is motivated by a changing cultural environment facilitated by emerging wireless technical capabilities. Economic, societal, and technical factors all play into the creation of how tomorrow's spectrum will be managed, and all these factors must have a role in determining how the next-generation radar is constructed. Radar operators, including the military, the Federal Aviation Administration, and weather forecasters all must be involved in the development of the next-generation radar, as well as wireless broadband companies, satellite operators, GPS interests, and other facets of the wireless community.

Conversations between radar engineers and wireless operators, such as the NTIA's International Symposium on Advanced Radio Technologies, and conferences organized by the DOD's Joint Spectrum Center must continue. As part of a grant that our Baylor research team recently received from the National Science Foundation, we will be establishing an annual Spectrum Forum at Baylor to facilitate discussions about spectrum solutions and research. This forum will be held annually in conjunction with the Texas Symposium on Wireless and Microwave Circuits and Systems, a conference that is technically cosponsored by the IEEE Microwave Theory and Techniques Society. A research task group, SET-182, set up by the North Atlantic Treaty Organization, has been organized in spectrum engineering. This panel serves as a forum for leading spectrum researchers in member countries to collaborate toward a solution for the spectrum problems we share. Leaders of the wireless communication industry must also participate in this discussion if the solution is to be successful. The way forward will involve collaboration from

all spectrum users. The present spectrum battles that are going on will not allow a solution that will benefit all. The answer to the spectrum crisis is not in spectral regulation, but in technical innovation. So, it seems, the way forward must involve open, honest, candid, and collaborative conversations between all involved stakeholders in the wireless spectrum.

Education of the next generation on these issues is also important (see Figure 15). The next generation will inherit the spectrum and the technology we provide it. Elementary, junior high, and high school students use the spectrum through cell phones and broadband devices, so understanding of the issues can be facilitated through the use of their everyday tools.

Conclusions

The spectrum environment is becoming more crowded, and next-generation radars must change how they operate. We predict that next-generation radars will be cognitive and reconfigurable; capable of operating in a DSA environment by frequency hopping and changing their transmitted spectrum to fit in the spectral environment they enter. To facilitate this, the next-generation radar must be able to change its circuitry and waveform in real time to operate successfully at different frequency and meet changing spectral requirements, while maintaining high power efficiency and accomplishing its range and Doppler detection objectives. Research in computationally intelligent algorithms for reconfiguring circuitry and waveforms, investigating the relationships between the circuit, waveform, and spectral spreading, and the implementation of this technology in a protocol where the spectral mask is changing will be necessary to move forward. As many of the concerns are societal and economic, mechanisms for discussion between the radar and wireless communications communities must be created and improved. Educating the next generation about wireless spectrum issues is also important. This article has discussed several ongoing efforts in creating this next-generation radar. Researchers continue to work in reconfigurable circuitry, waveforms, and spectrally compliant designs, and such research will be necessary to build a radar that will facilitate the spectrum of tomorrow.

Acknowledgments

This work has been partially funded by a grant from the National Science Foundation (Award Number ECCS-1343316). We wish to thank Agilent Technologies for donating the Advanced Design System software.

References

- [1] NBC News. (2009, Oct.). FCC warns of mobile's looming spectrum crisis. [Online]. Available: <http://www.nbcnews.com>
- [2] (2010, Mar.). The National Broadband Plan. [Online]. Available: <http://www.broadband.gov/plan>

- [3] (2011, July). National Telecommunications and Information Administration. [Online]. Available: <http://www.ntia.doc.gov>
- [4] C. Baylis, L. Cohen, and R. Jost, "Introduction to radar transmitters," presented at *IEEE Radar Conf.*, Kansas City, MO, May 2011.
- [5] S. Haykin, "Cognitive radar: A way of the future," *IEEE Signal Processing Mag.*, vol. 23, pp. 30–40, Jan. 2006.
- [6] J. Guerci, *Cognitive Radar: The Knowledge-Aided Fully Adaptive Approach*. Norwood, MA: Artech House, 2010.
- [7] D. Qiao, R. Molfino, S. Lardizabal, B. Pillans, P. Asbeck, and G. Jerinic, "An intelligently controlled RF power amplifier with a Reconfigurable MEMS-varactor tuner," *IEEE Trans. Microwave Theory Tech.*, vol. 53, no. 3, pt. 2, pp. 1089–1095, Mar. 2005.
- [8] C. Baylis, L. Dunleavy, S. Lardizabal, R. J. Marks II, and A. Rodriguez, "Efficient optimization using experimental queries: A peak-search algorithm for efficient load-pull measurements," *J. Adv. Comput. Intell. Intell. Inform.*, vol. 15, no. 1, pp. 13–20, Jan. 2011.
- [9] L. Patton, "On the satisfaction of modulus and ambiguity function constraints in radar waveform optimization for detection," Ph.D. dissertation, Dept. Elec. Eng., Wright State Univ., Fairborn, OH, 2007.
- [10] J. M. Chapin and W. H. Lehr, "The path to market success for dynamic spectrum access technology," *IEEE Commun. Mag.*, vol. 45, no. 8, pp. 96–103, May 2007.
- [11] Q. Zhao and B. M. Sadler, "A survey of dynamic spectrum access: Signal processing, networking, and regulatory policy," *IEEE Signal Processing Mag.*, vol. 24, no. 3, pp. 79–89, May 2007.
- [12] J. de Graaf, H. Faust, J. Alatishe, and S. Talapatra, "generation of spectrally confined transmitted radar waveforms," in *Proc. IEEE Conf. Radar*, 2006, pp. 76–83.
- [13] C. Baylis, L. Wang, M. Moldovan, J. Martin, H. Miller, L. Cohen, and J. de Graaf, "Designing transmitters for spectral conformity: Power amplifier design issues and strategies," *IET Radar, Sonar, Navig.*, vol. 5, no. 6, pp. 681–685, July 2011.
- [14] C. Baylis, L. Wang, M. Moldovan, J. Martin, H. Miller, L. Cohen, and J. de Graaf, "Designing for spectral conformity: Issues in power amplifier design," in *Proc. IEEE Waveform Diversity Conf.*, Niagara Falls, ON, Canada, Aug. 2010, pp. 000220–000223.
- [15] F. Raab, P. Asbeck, S. Cripps, P. Kenington, Z. Popovic, N. Pothecary, J. Sevic, and N. Sokal, "RF and microwave power amplifier and transmitter topologies, Part 1," *High Freq. Electron.*, vol. 2, no. 3, pp. 22–40, May 2003.
- [16] F. Raab, P. Asbeck, S. Cripps, P. Kenington, Z. Popovic, N. Pothecary, J. Sevic, and N. Sokal, "Power amplifiers and transmitters for RF and microwave," *IEEE Trans. Microwave Theory Tech.*, vol. 50, no. 3, pp. 814–826, Mar. 2002.
- [17] M. Cook, "CPM-based radar waveforms for efficiently bandlimiting a transmitted spectrum," M.S. thesis, Dept. Elec. Eng. and Comput. Sci., Univ. Kansas, Lawrence, KS, Apr. 2010.
- [18] H. Faust, B. Connolly, T. Firestone, R. Chen, B. Cantrell, and E. Mokole, "A spectrally clean transmitting system for solid-state phased array radars," in *Proc. IEEE Radar Conf.*, 2004, pp. 140–144.
- [19] R. J. Marks II, *Handbook of Fourier Analysis and Its Applications*. London, U.K.: Oxford Univ. Press, 2009.
- [20] J. Sevic, "Large signal automated load-pull characterization of adjacent-channel power ratio for digital wireless communication systems," in *IEEE MTT-S Int. Microwave Symp. Dig.*, June 1996, pp. 763–766.
- [21] J. Sevic, K. Burger, and M. Steer, "A novel envelope-termination load-pull method for ACPR optimization of RF/microwave power amplifiers," in *IEEE MTT-S Int. Microwave Symp. Dig.*, June 1998, vol. 2, pp. 723–726.
- [22] Q. Wu, H. Xiao, and F. Li, "Linear power amplifier design for CDMA signals: A spectrum analysis approach," *Microw. J.*, vol. 41, pp. 22–40, Dec. 1998.
- [23] Y. Lu, D. Peroulis, S. Mohammadi, and L. Katehi, "A MEMS reconfigurable matching network," *IEEE Microwave Wireless Compon. Lett.*, vol. 13, no. 10, pp. 437–439, Oct. 2003.
- [24] T. Vaka-Heikkila and G. Rebeiz, "A 4–18-GHz reconfigurable RF MEMS matching network for power amplifier applications," *Int. J. RF Microw. Comput.-Aided Eng.*, vol. 14, no. 4, pp. 356–372, July 2004.
- [25] N. Deve, A. Kouki, and V. Nerguizian, "A compact size reconfigurable 1–3-GHz impedance tuner suitable for RF MEMS applications," in *Proc. 16th Int. Conf. Microelectronics*, Dec. 6–8, 2004, pp. 101–104.
- [26] Y. Sun, J. Moritz, and X. Zhu, "Adaptive Impedance matching and antenna tuning for green software-defined and cognitive radio," in *Proc. 54th IEEE Int. Midwest Symp. Circuits Systems*, 2011, pp. 1–4.
- [27] Y. Sun, "Evolutionary tuning method for automatic impedance matching in communication Systems," in *Proc. IEEE Int. Conf. Electronics, Circuits Systems*, 1998, vol. 3, pp. 73–77.
- [28] Y. Sun and W. K. Lau, "Antenna impedance matching using genetic algorithms," in *Proc. IEE Conf. Antennas Propagation*, York, U.K., Aug. 1999, pp. 31–36.
- [29] W. du Plessis and P. Abrie, "Lumped impedance matching using a hybrid genetic algorithm," *Microw. Opt. Technol. Lett.*, vol. 37, no. 3, pp. 210–212, May 2003.
- [30] E. Arroyo-Huerta, A. Diaz-Mendez, J. Ramirez-Cortes, and J. Garcia, "An adaptive impedance matching approach based on fuzzy control," in *52nd IEEE Int. Midwest Symp. Circuits Systems*, Aug. 2009, pp. 889–892.
- [31] J. Hemminger, "Antenna impedance matching with neural networks," *Int. J. Neural Syst.*, vol. 15, no. 5, pp. 357–361, 2005.
- [32] A. Mushi, D. Johns, and A. Sedra, "Adaptive impedance matching," in *Proc. IEEE Int. Symp. Circuits Systems*, 1994, vol. 2, pp. 69–72.
- [33] C. Baylis, S. Lardizabal, and L. Dunleavy, "A fast sequential load-pull algorithm implemented to find maximum output power," in *Proc. IEEE Wireless Microwave Technology Conf.*, Clearwater, FL, Dec. 2006, pp. 1–4.
- [34] D. Wilde, *Optimum Seeking Methods*. Englewood Cliffs, NJ: Prentice-Hall, 1964.
- [35] J. Martin, "Adaptive load impedance optimization for power amplifiers in reconfigurable radar transmitters," M.S. thesis, Dept. Electr. Comput. Eng., Baylor Univ., Waco, TX, 2012.
- [36] M. Fellows, C. Baylis, J. Martin, L. Cohen, and R. J. Marks II, "Direct algorithm for the Pareto load-pull optimization of power-added efficiency and adjacent-channel power ratio," *IET Radar, Sonar Navig.*, to be published.
- [37] M. Skolnik, *Introduction to Radar Systems*, 3rd ed. New York: McGraw-Hill, 2001.
- [38] M. Fellows, C. Baylis, L. Cohen, and R. J. Marks II, "Radar waveform optimization to minimize spectral spreading and achieve target detection," in *Proc. Texas Symp. Wireless Microwave Circuits Systems*, Waco, TX, Apr. 2013, pp. 1–4.
- [39] P. M. Woodward, *Probability and Information Theory, with Applications to Radar*. New York: Pergamon Press, 1953.
- [40] C. Wilcox, "The synthesis problem for radar ambiguity functions," Dept. Elec. and Comput. Sci., Univ. Wisconsin, Madison, MRC Tech. Summary Rep. 156, 1960.
- [41] I. Gladkova and D. Chebanov, "A new extension of Wilcox's Method," in *Proc. 5th WSEAS Int. Conf. Applied Mathematics*, Miami, FL, 2004, pp. 1–6.
- [42] I. Gladkova and D. Chebanov, "On the synthesis problem for a waveform having a nearly ideal ambiguity surface," in *Proc. Int. Radar Conf.*, Toulouse, France, Oct. 2004.
- [43] S. Sen and A. Nehorai, "Adaptive design of OFDM radar signal with improved wideband ambiguity function," *IEEE Trans. Signal Process.*, vol. 58, no. 2, pp. 928–933, Feb. 2010.
- [44] J. C. Holtzman and J. S. Thorp, "Optimum Signals for Radar," *IEEE Trans. Aerosp. Electron. Syst.*, vol. 5, no. 6, pp. 898–905, Nov. 1969.
- [45] K. T. Wong and W.-K. Chung, "Pulse-diverse radar/sonar FSK-PSK waveform design to emphasize/de-emphasize designated doppler-delay sectors," in *Proc. Rec. IEEE Int. Radar Conf.*, Alexandria, VA, May 7–12, 2000, pp. 745–749.
- [46] S. Sussman, "Least-square synthesis of radar ambiguity functions," *IRE Trans. Inform. Theory*, vol. 8, no. 3, pp. 246–254, Apr. 1962.
- [47] S. Blunt, M. Cook, E. Perrins, and J. de Graaf, "CPM-based radar waveforms for efficiently bandlimiting a transmitted spectrum," in *Proc. IEEE Radar Conf.*, 2009, pp. 1–6.
- [48] C. Baylis, R. J. Marks II, J. Martin, H. Miller, and M. Moldovan, "Going nonlinear," *IEEE Microwave Mag.*, vol. 12, no. 2, pp. 55–64, Apr. 2011.
- [49] C. Baylis and R. J. Marks II, "Small perturbation harmonic coupling in nonlinear periodicity preservation circuits," *IEEE Trans. Circuits Syst. I*, vol. 59, no. 12, pp. 3034–3045, Dec. 2012.
- [50] C. Baylis and R. J. Marks II, "Evaluation of harmonic coupling weights in nonlinear periodicity preservation systems," *IEEE Trans. Circuits Syst. I*, vol. 59, no. 12, pp. 3024–3033, Dec. 2012.

